

Time-Current Curve

A graph showing how long before a circuit breaker will trip at each level of fault current.

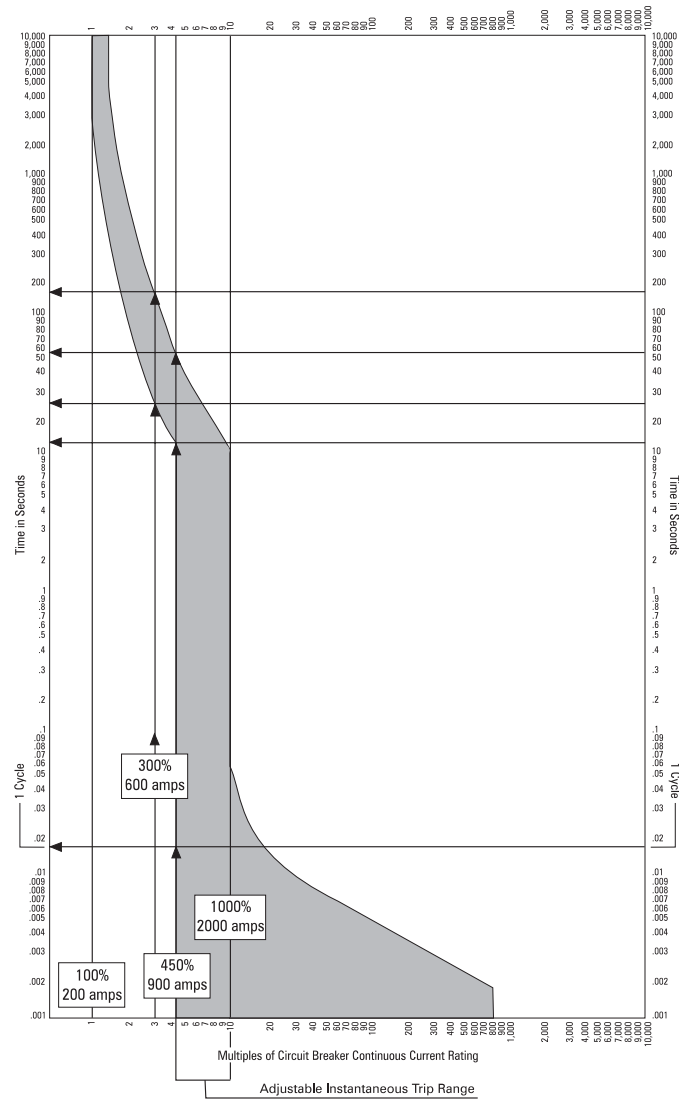

Timing Relay

A control device that opens or closes its contacts after a time delay. Some timing relays begin the time delay when the relay is energized. Others begin the time delay when the relay is de-energized.

Torque

A turning or twisting force. Since torque is expressed as a force times the length of the radius at which the force is measured, torque is represented in compound units such as pound-feet (lb.-ft.)

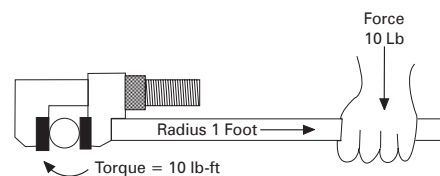

Total Harmonic Distortion (THD)

The ratio of *harmonic distortion* to the fundamental *frequency*. The greater the THD the more distortion there is.

$$\% \text{ of THD} = \frac{\text{RMS of Total Harmonic Distortion Signal}}{\text{RMS of Fundamental Frequency}} \times 100$$

Totally Enclosed Fan Cooled (TEFC)

A motor *enclosure* type that restricts the flow of air into or out of the motor, but uses a fan to blow air over the motor's exterior.

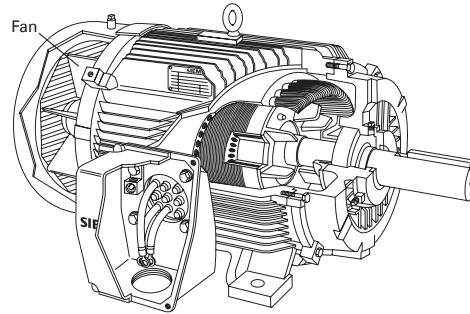

Totally Enclosed Non-ventilated (TENV)

A motor *enclosure* type that restricts the flow of air into or out of the motor.

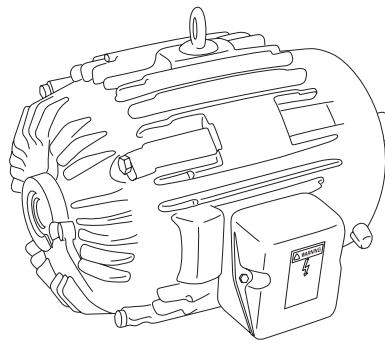

Totally Integrated Automation (TIA)

A strategy developed by Siemens that emphasizes the seamless integration of automation products.

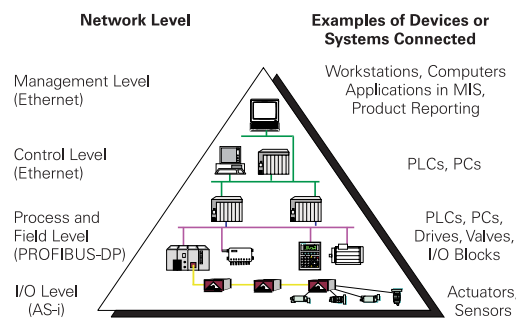

Transducer

A device that converts energy from one form to another. Often refers to sensing devices used to monitor or control a process.

Transformer

Coils of wire wound on a common frame that allow electrical energy to be transferred from one circuit to another.

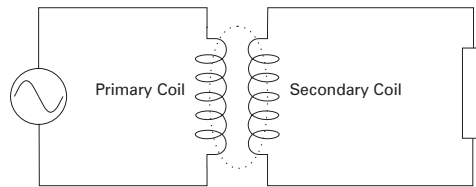

Transistor

A *semiconductor* device which usually has three terminals although the names of the terminals are different for different types of transistors. Some types of transistors are used as electronic switches.

Trim

The front cover of a panel, often including an access door.

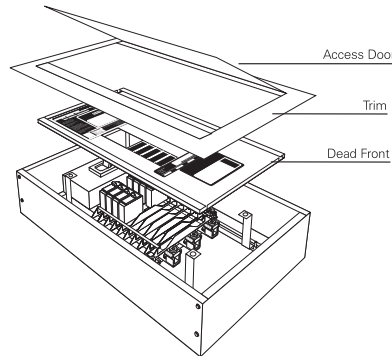

Trip Unit

The part of the *circuit breaker* that can be manually or electronically set to determine under what conditions its contacts will automatically open.

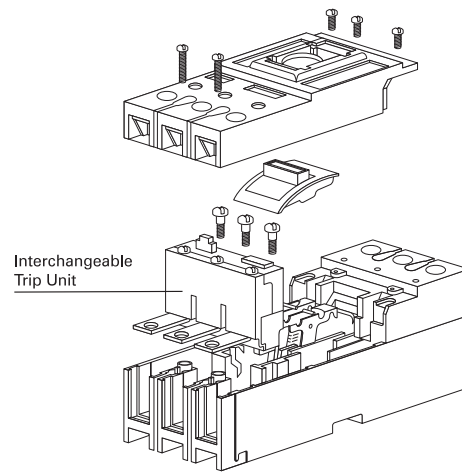

True Power

Also called real power, true power is power dissipated by circuit resistance. True power is equal to I^2R and is measured in watts. True power is also equal to the apparent power multiplied by the power factor.

Ultrasonic Sensor

A type of sensing switch that uses high frequency sound to detect the presence of an object without coming into contact with the object.

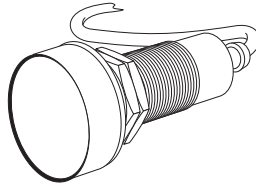

Underwriter's Laboratory (UL)

A private company that is nationally recognized as an independent testing laboratory. UL tests products for safety. Products that pass UL tests can carry a UL label. UL has several categories of labels based upon the type of product tested.

Unit Substation

A coordinated design consisting of one or more transformers mechanically and electrically linked to switchgear or switchboard assemblies.

Var

The basic unit for reactive power. Shortened from volt-ampere reactive.

Variable Frequency Drive (VFD)

An electronic device used to control the speed and torque of an AC motor. Also called an AC drive.

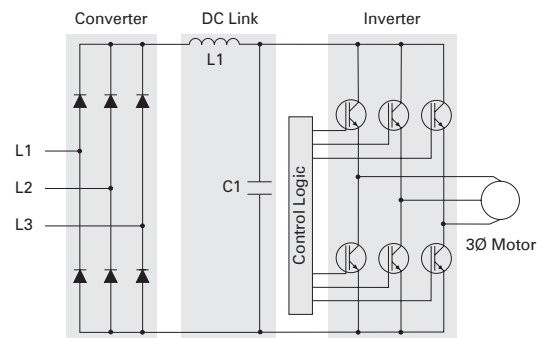

Variable Speed Drive

An electronic drive device to control the speed and *torque* of either an AC or DC motor. Also called an adjustable speed drive.

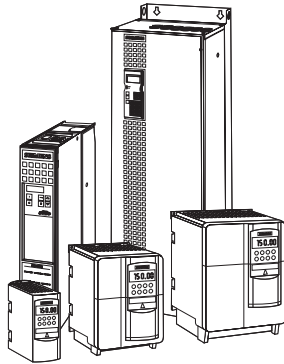

Vector Control

Describes a technique employed by some *variable frequency drives* that uses a complex mathematical model of a motor to provide excellent control of speed and *torque*.

Volt

The basic unit of *voltage*. The symbol for volt is "V."

Voltage

Also called difference of potential, *electromotive force*, or emf. Voltage is a force that when applied to a *conductor* causes *current* to flow. Voltage is symbolized by "E" or "V" and is measured in *volts*.

Voltmeter

A meter designed to measure *voltage*.

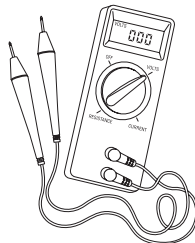

Volts per Hertz (V/Hz) Operation

Describes the operation of many *variable frequency drives* that control the speed of an AC motor by varying the *frequency* of the *voltage* applied to the motor while attempting to maintain a voltage to frequency ratio.

Watt

The basic unit of electric *power*. The symbol for watt is "W."

Watt-Hour Meter

A meter designed to measure electrical energy usage.

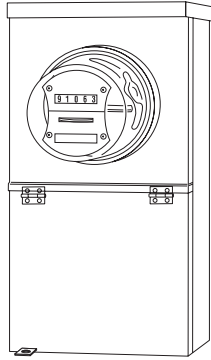

Word

Usually one or more bytes used to represent instructions or data in digital equipment.

Wye

A connection arrangement used for the primary and/or secondary of a three-phase transformer.

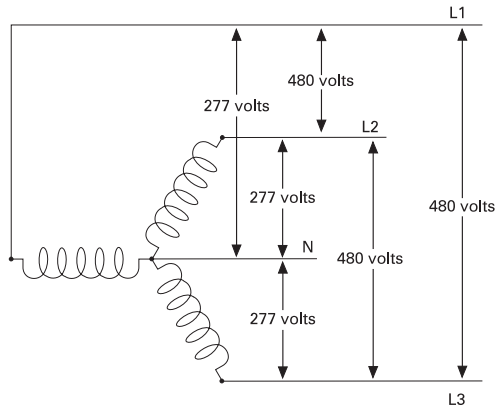

Review Answers

Review 1

1) generator; 2) step-up; 3) 120; 4) 120; 5) Lateral service; 6) six;
7) surge arrester; 8) GFCI.

Review 2

1) C; 2) TPS; 3) distribution; 4) SMM; 5) 4000.

Review 3

1) low; 2) 16.5; 3) SR; 4) transformer; 5) Feeder.

Review 4

1) b; 2) c; 3) 24; 4) SINUMERIK®.

Review 5

1) Reduced voltage; 2) drive; 3) PROFIBUS; 4) ASI; 5) batch;
6) Closed-loop.

Final Exam

The final exam is intended to be a learning tool. The book may be used during the exam. A tear-out answer sheet is provided. After completing the test, mail the answer sheet in for grading. A grade of 70% or better is passing. Upon successful completion of the test a certificate will be issued.

Questions

1. The most efficient way to transmit energy from a power company to the utility's customer via transmission lines is to _____.
 - a. Increase voltage and current
 - b. Increase voltage and reduce current
 - c. Decrease voltage and increase current
 - d. Decrease voltage and current

2. The *National Electrical Code*® requires _____ for all branch circuits that supply 125-volt, single-phase, 15- and 20-amp receptacle outlets installed in dwelling unit bedrooms.
 - a. Arc Fault Circuit Interrupters
 - b. Circuit Breaker/Surge Arresters
 - c. Ground Fault Circuit Interrupters
 - d. TPS

3. _____ is a motor starter manufactured by Siemens.
 - a. TIASTAR
 - b. S7-200
 - c. INNOVA PLUS™
 - d. SINUMERIK®

4. According to the *National Electrical Code*® (*NEC*®), _____ may be accessible from the rear as well as the front.
 - a. load centers
 - b. panelboards
 - c. switchboards
 - d. all of the above

5. _____ is a product used in Siemens busway, panelboards, switchboards, and switchgear to protect electrical equipment from damage due to electrical surges.
- a. TPS
 - b. PROFIBUS
 - c. GFCI
 - d. GMI
6. Type _____ switchboards are commercial metering switchboards designed to meet west coast utility specifications.
- a. MMS
 - b. SPB
 - c. TPS
 - d. SMM
7. _____ is the trade name for the Siemens power management and control system.
- a. ACCESS
 - b. TIA
 - c. PROFIBUS
 - d. SIMATIC®
8. _____ is a type of circuit breaker used in Siemens low voltage switchgear.
- a. GFCI
 - b. Single-pole
 - c. NXAIR P
 - d. Type RL
9. _____ is a trade name for Siemens regulated power supplies.
- a. HMI
 - b. TPS
 - c. SITOP®
 - d. Sentron™
10. SINUMERIK® CNC models, such as 810D, 840Di, and 840D are Siemens products used to _____ .
- a. distribute power throughout a building
 - b. provide precise control for machine tools
 - c. control lighting in a large commercial building
 - d. control above NEMA motors
11. _____ is a LAN used primarily at the device level.
- a. Ethernet
 - b. ASI
 - c. PROFIBUS DP
 - d. PROFIBUS PA

12. _____ is an alternative approach to distributed control systems (DCS) used for process control.
- a. SIMATIC® PCS 7
 - b. Closed-loop control
 - c. WinCC®
 - d. PROFIBUS SMS
13. _____ refers to any device that acts as a link between the operator and the machine.
- a. SMM
 - b. AWG
 - c. MMS
 - d. HMI
14. _____ is the trade name for a Siemens motor control center.
- a. NXAIR P
 - b. SIRIUS
 - c. SIMATIC® HMI
 - d. TIASTAR
15. Medium voltage equipment is rated _____ .
- a. for 480 volts
 - b. for 1000 volts or less
 - c. greater than 1000 to 100,000 volts
 - d. greater than 100,000 to 230,000 volts
16. Which of the following is an HMI product?
- a. AC motor
 - b. WinCC®
 - c. Switchboard
 - d. Motor starter
17. _____ is a control technique that compares a feedback signal representative of an actual value with a desired value and responds to minimize the error.
- a. Open-loop control
 - b. Closed-loop control
 - c. Discrete control
 - d. Continuous control

18. Standards that correspond to a motor's speed and torque characteristics are published by _____.
- a. NEMA
 - b. UL
 - c. ISA
 - d. *NEC*[®]
19. The _____ publishes the *National Electrical Code*[®].
- a. National Electrical Manufacturers Association
 - b. Underwriter Laboratories, Inc.
 - c. National Fire Protection Association
 - d. Institute of Electrical and Electronic Engineers
20. _____ is the trade name of one type of medium voltage switchgear manufactured by Siemens that features an "arc vented" design.
- a. RCIII
 - b. 5 - 15 kV
 - c. 38 KV
 - d. NXAIR P

NEC[®] and *National Electrical Code*[®] are registered trademarks of the National Fire Protection Association.

Notes

quickSTEP Online Courses

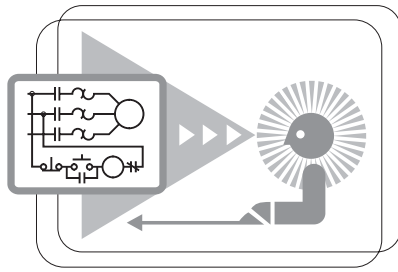

quickSTEP online courses are available at <http://www.sea.siemens.com/step>.

The quickSTEP training site is divided into three sections: Courses, Downloads, and a Glossary. Online courses include reviews, a final exam, the ability to print a certificate of completion, and the opportunity to register in the Sales & Distributor training database to maintain a record of your accomplishments.

From this site the complete text of all STEP 2000 courses can be downloaded in PDF format. These files contain the most recent changes and updates to the STEP 2000 courses.

A unique feature of the quickSTEP site is our pictorial glossary. The pictorial glossary can be accessed from anywhere within a quickSTEP course. This enables the student to look up an unfamiliar word without leaving the current work area.

